

Centrifugal Separator Clarifier for Bacteria Removal



THE PRODUCT

MAXCLEAN BACTERIA is a centrifugal separator configured as clarifier (2-phase), for dairy application, with paring discs, partial and total automatic discharge capabilities, and ready for Clean-In-Place (CIP).

THE APPLICATION

MAXCLEAN BACTERIA has been designed by HAUS for the removal of bacteria in milk. Its purpose is to remove the solid impurities, either organic or not organic, before the milk processing taking place. Thanks to its recirculating pump and superior design it is effective in cleaning aerobic and anaerobic spores as well as bacteria and somatic cells.

MAXCLEAN BACTERIA reduces the number of spores and total bacteria count in the milk with high efficiency, resulting in a longer shelf life and higher product quality.

SPECIAL FEATURES

MAXCLEAN BACTERIA belongs to a new generation of separators, designed exclusively for dairy application.

Highest level of efficiency is achieved, whilst the product is treated gently, preserving high hygiene.

Thanks to advanced features like:

- High Rotational Speed: generating a huge centrifugal force, thanks to quality material and mechanics.
- Disc Stack: closely spaced discs of large diameter, creating a large surface of separation
- Submerged Feed Pipe: a system to introduce and accelerate the product gently, minimizing shear stress, oxygen pick-up and foaming
- Recirculation Pump; spores, somatic cells and bacteria in the intense areas of the feed, returns to the inlet for effective cleaning.
- Extended shelf life; It helps to extend the shelf life by reducing the number of spores, somatic cells and bacteria found in the products.
- Double Valve Discharge System: able to perform very fast and precise discharges of limited bowl portions, for reduced loss of milk and valuable components (fat, protein)
- Paring Disc Outlet with Counter-Pressure Valve: to regulate the bowl load and activate the Submerged Feed Pipe system.
- Strict Hygienic Configuration: quality material, polished discs, fine treatment of contact surfaces to avoid product deposit, and an optional CIP system
- Easy Drive: VFD for smooth start and stops without friction clutch and with lowest possible energy consumption, PLC for automatic control of centrifuge separation and CIP sequence, HMI to adjust operational parameters and to monitor alarms.
- High Stability Basement, made in heavy cast iron covered with stainless steel cladding.

APPLICATIONS

- milk cleaning
- removal of bacteria
- extended shelf life

HIGHLIGHTS

- separation efficiency
- removal of solid
- somatic cell removal
- spore reduction
- recirculating pump
- gentle treatment
- efficient discharging
- hygienic design
- quality material
- CIP ready
- parameter optimization
- energy saving

OPERATING PRINCIPLES

The product mixture is introduced in the bowl, where it is put on rotation. The centrifugal force results in the product being separated by the solid according to density difference. The milk is forced to flow through tiny spaced discs, which allows also the smaller particle to deposit and being driven apart.

The cleaned liquid overflows from the central outlet, through a paring disc (centripetal pump), to exit under pressure. The counter-pressure valve on the outlet pipe can be adjusted to regulate the liquid load inside the bowl (submerged feed pipe system).

Heavier solid particles accumulate in the sludge volume of the bowl periphery, from where are discharged periodically. During partial discharge operation, only the sludge volume is emptied. Differently, the total discharge operation empties the entire bowl volume. Any sequence of partial and total discharge can be programmed into the PLC via the HMI interface, such that it is carried over by the automatic control system

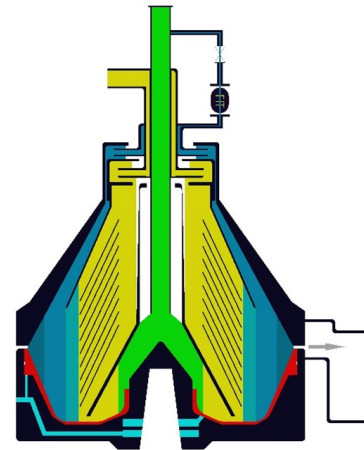

STANDART CONFIGURATION

- control panel with PLC and HMI
- operating water booster pump
- electrical motor with VFD
- set of special tools and parts for commissioning
- operator manuals

OPTIONALS

- flow control accessories
- product feed pump and feed valve
- CIP (Cleaning In Place) system

TECHNICAL DATA

Capacity, milk clarification*	up to 25.000 L/h
Bowl/ Sludge Volume	42 / 8 L
Installed Motor Power	45 kW
Separator weight (total, empty)	2650 kg
Bowl weight (alone, empty)	785 kg
Noise level	85 dB(A)
Dimension (LxW, H)	1940x1200, 2660

* Nominal capacity, corresponding to specific process condition

MAIN MATERIALS

Bowl Body	EN1.4418
Bowl Hood and Sliding Piston	Duplex EN1.4462
Discs	AISI 316 EN1.4401
Other Contact Surfaces	AISI 304 EN1.4301
Cover, Sludge Collector	AISI 304 EN1.4301
Separator Frame	Cast Iron with Stainless Steel cladding

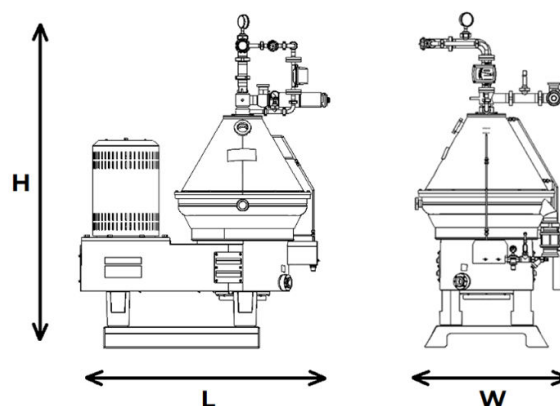

CUSTOMER SATISFACTION



USER FRIENDLY



RELIABLE & QUALIFIED SERVICE



CONTINUOUS SERVICE



ORIGINAL SPARE PARTS